

REV.	ECN.NO.	MODIFY.CONTENT

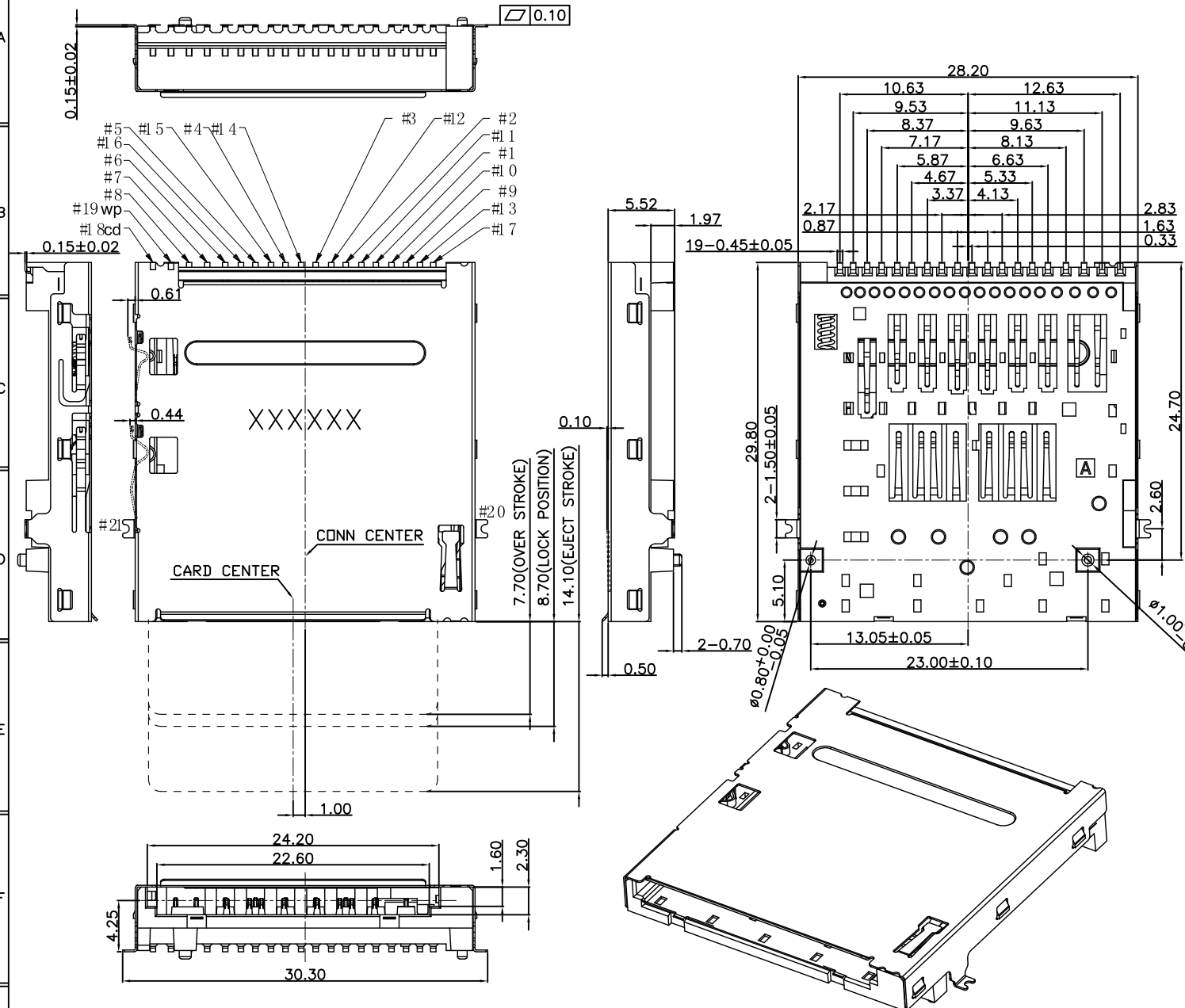

NOTES :

1. MATERIAL :
 - 1.1 HOUSING:LCP UL94 V-0, BLACK COLOR.
 - 1.2 SHELL:STAINLESS STEEL.
 - 1.3 CONTACT:COPPER ALLOY.
2. FINISH :
 - 2.1 CONTACT: GOLD PLATING ON CONTACT AREA, MATTE TIN 100u"MIN ON SOLDERTAIL AREA. 50u" MIN NICKEL PLATING OVERALL.
 - 2.2 SHELL: 30U" MIN SOLDERABLE NICKEL PLATED OVER ALL. GOLD FLASH ON SOLDERTAIL AREA.
3. ELECTRICAL CHARACTERISTICS:
 - 3.1 OPERATING VOLTAGE : 100V AC(rms)/DC.
 - 3.2 CURRENT RATING : 0.5 A.
 - 3.3 OPERATING TEMPERATURE: -25°C~+85°C.
 - 3.4 CONTACT RESISTANCE: 100 m OHMS MAX.
 - 3.5 INSULATION RESISTANCE: 1000M OHMS MIN. AT 250VDC.
 - 3.6 DIELECTRIC WITHSTANDING VOLTAGE:500 VAC/1MINUTE.

PART.NO.:

TW151-AP401-**

- 42: 功能区镀金1U", 锡脚镀雾纯锡至少100U"
- 43: 功能区镀金3U", 锡脚镀雾纯锡至少100U"
- 44: 功能区镀金5U", 锡脚镀雾纯锡至少100U"
- 45: 功能区镀金10U", 锡脚镀雾纯锡至少100U"
- 46: 功能区镀金15U", 锡脚镀雾纯锡至少100U"
- 47: 功能区镀金30U", 锡脚镀雾纯锡至少100U"

GENERAL	TOLERANCE	DWG.NO.	TW151-AP401-00	PART.NO.	TW151-AP401-**	DRAWN	L.M.J 2017.09.25
x.±0.50	x. °± 5°	REV.	A	TITLE	SD4.0 Push H5.52 CONN	CHECKED	
.x±0.25	.x °± 2°	SIZE		SHEET	1 OF 3	APPROVED	
.xx±0.15	.xx °± 1°	A4					

OLN 东莞市欧联电子科技有限公司
DONGGUAN OLN ELECTRONICS TECHNOLOGY CO., LTD.

REV.	ECN.NO.	MODIFY.CONTENT
------	---------	----------------

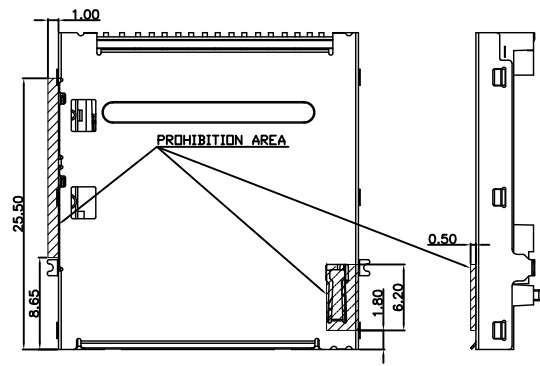
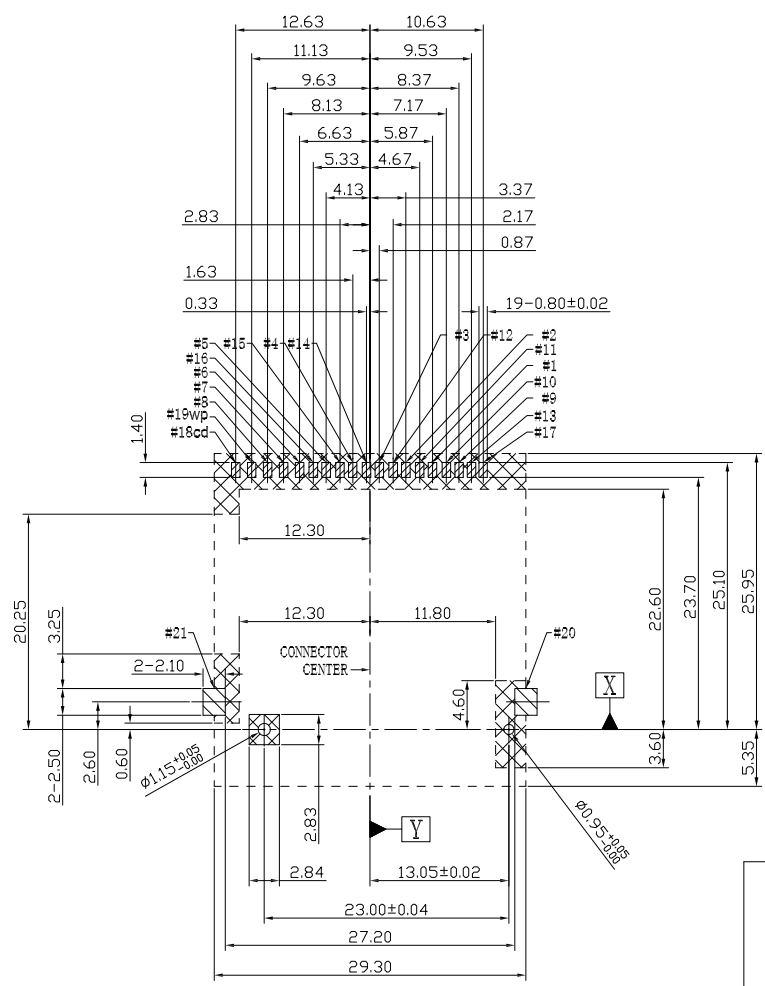

RECOMMEND P. C. BOARD LAYOUT (TOP VIEW)
TOLERANCE UNLESS OTHERWISE SPEC ± 0.05

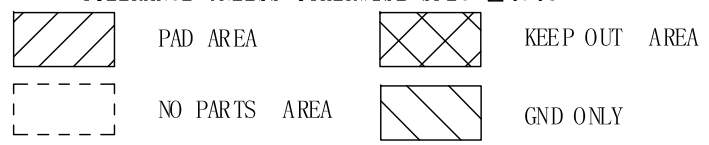

NO.	SD NAME	USH-LL NAME
1	CD/DAT3	
2	CMD	
3	VSS1	VSS1
4	VDD	VDD1
5	CLK	
6	VSS2	VSS2
7	DAT0	RCLK+
8	DAT1	RCLK-
9	DAT2	
10		VSS3
11		DO+
12		DO-
13		VSS4
14		VDD2
15		D1-
16		D1+
17		VSS5
18	CD SW	
19	WP SW	
20	GND SW	
21	GND SW	

	W/P CONTACT		C/D CONTACT
	WRITE PROTECT POSITION	WRITE ENABLE POSITION	
CARD UNINSERTION	CLOSE	CLOSE	CLOSE
CARD HALF INSERTION	OPEN	OPEN	CLOSE
CARD INSERTION	CLOSE	OPEN	OPEN

GENERAL TOLERANCE	DWG.NO.	TW151-AP401-00	PART.NO.	TW151-AP401-**	DRAWN	L.M.J 2017.09.25
x.±0.50	REV.	A	TITLE	SD4.0 Push H5.52 CONN	CHECKED	
.x±0.25	SIZE	A4	SHEET	2 OF 3	APPROVED	
.xx±0.15						

UNIT mm SCALE 1:1

OLN 东莞市欧联电子科技有限公司
DONGGUAN OLN ELECTRONICS TECHNOLOGY CO., LTD.

东莞市欧联电子科技有限公司

包装作业规范

REV.	ECN.NO.	MODIFY.CONTENT
------	---------	----------------

包装作业图示及说明 (PACKING OPERATION DIAGRAM & INSTRUCTION)

- 一.
- 1) 将成品一一放入REEL包装盘内,依同一方向放入.
 - 2) 包装时,如图所示.
 - 3) 一个REEL包装盘放置250个成品.

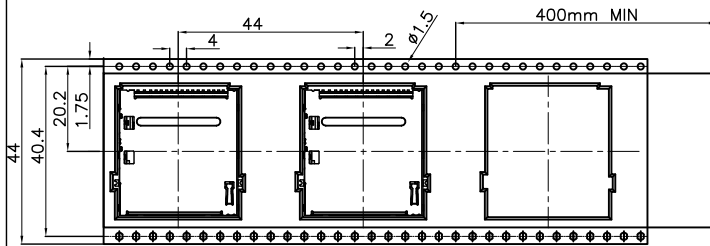

- 二.
- 1) 装盘前先把前面空10pcs产品,然后再开始装盘, 尾端也需空10pcs产品.
 - 2) 装满成品的REEL包装盘如下图所示.

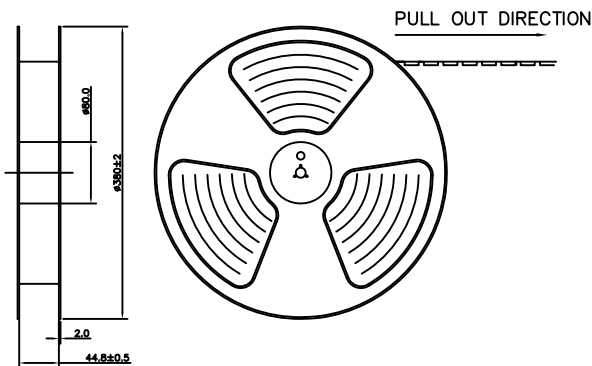

- 三.
- 1) 每箱装 6 盘REEL包装盘.
 - 2) 每箱放置 1500 PCS 的成品.

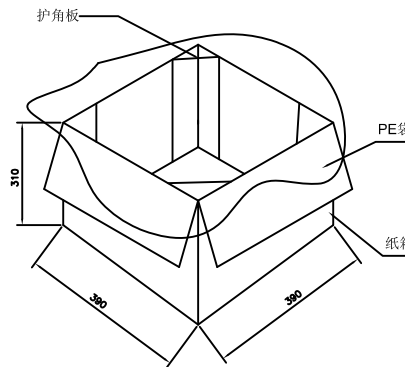
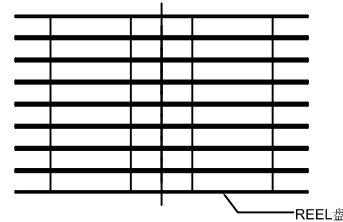

- 四.
- 1) 用TAPE将纸箱封实.

ITEM NO:	PCS
QTY:	KGS
G.W.:	KGS
N.W.:	KGS
MEAS:	cm

C/NO:
MADE IN CHINA

備註 (REMARK)

1. 若有未裝滿之零數箱,必須以緩衝材塞滿.

GENERAL TOLERANCE	DWG.NO.	TW151-AP401-00	PART.NO.	TW151-AP401-**	DRAWN	L.M.J 2017.09.25
x.±0.50	REV.	A	TITLE	SD4.0 Push H5.52 CONN	CHECKED	
.x±0.25	SIZE		SHEET	3 OF 3	APPROVED	
.xx±0.15	A4					

UNIT	mm	SCALE	1:1
OLN 东莞市欧联电子科技有限公司 DONGGUAN OLN ELECTRONICS TECHNOLOGY CO., LTD.			